

Promate®

Operator Manual

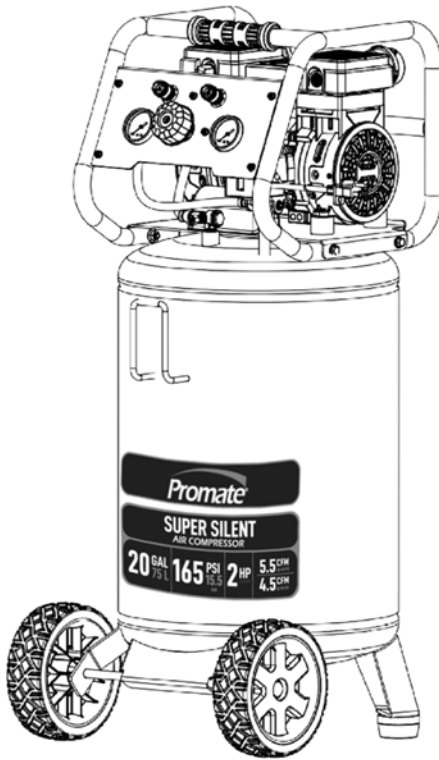

AIR COMPRESSOR

IMPORTANT – Please make certain that persons who are to use this equipment thoroughly read and understand these instructions and any additional instructions provided before operation.

Record the model and serial numbers of your Air compressor below:

Model No. _____ Serial No. _____

FOREWORD

Thank you for purchasing Promate PCSS2020. This operator manual is for proper handling, minor checking, and maintenance of the PCSS2020. Before using your air compressor: Please read these instructions completely and carefully to operate it safely and make the best use of it. Due to constant efforts to improve our products, certain procedures and specifications are subject to change without notice, if you have any questions, please contact Promate Service.

Contents

1	Safety Precautions.....	1
	1.1 Safety Instructions.....	2
2	Parts and Specifications.....	4
3	Tool Compatibility Chart.....	5
4	Important Information	6
5	Product Features.....	6
6	Assembly.....	6
	6.1 Packaging Contents.....	6
	6.2 Positioning the Air Compressor.....	6
7	Operation.....	7
	7.1 Before Starting.....	7
	7.2 Starting the Compressor.....	7
	7.3 Stopping the Compressor.....	8
	7.4 Draining the Tank.....	9
8	Maintenance and Storage.....	9
9	Troubleshooting.....	10
10	Service Information.....	11
11	Exploded Diagram & Part List	12











Diagram	Title	Page
1	Electrical Safety Guide.....	3
2	Minimum Gauge for Extension Cords.....	3
3	Air Compressor Parts.....	4
4	Figure A.....	7
5	Figure B.....	7
6	Figure C.....	7
7	Figure D.....	7
8	Figure E.....	7
9	Figure F.....	8
10	Figure G.....	8
11	Figure H.....	8
12	Figure I.....	8
13	PCSS2020 Exploded View	12
14	PCSS2020 Motor Pump Head Exploded View	13

Table	Title	Page
1	Safety Symbols and Meanings.....	1
2	General Specifications.....	4
3	Tool Compatibility Chart.....	5
4	Packaging Contents.....	6
5	Maintenance and Storage.....	9
6	Troubleshooting.....	10
7	PCSS2020 Parts List.....	12
8	PCSS2020 Motor Pump Head Parts List.....	13

1. Safety Precautions

When handling this unit, please keep to the following matters. Please make sure you review each precaution carefully. You must also make sure that the procedure, work method, or operating technique that you choose does not render the compressor unsafe.

Table 1. Safety Symbols and Meanings

V	Volts	Voltage
A	Amperes	Current
Hz	Hertz	Frequency (cycles per second)
W	Watts	Power
~	Alternating current	Type of current
---	Direct current	Type of characteristic of current
	No-load speed	Rotational speed, at no load
lbs.	Pounds	Weight
.../min	Per minute	Revolutions, strokes, surface speed orbits, etc. per minute
	Class II construction	Double-insulated construction
	Read the operator's manual	To reduce the risk of injury, read and understand the operator's manual
	Wear safety glasses	Operation of power tools can result in foreign objects being thrown into the eyes
	Wear respiratory protection	Use of this tool can generate dust which may cause respiratory injury
	Wear hearing protection	Noise from this product can contribute to hearing loss
	Wear gloves	Wear gloves to reduce the risk of injury
	Safety Alert Symbol	Alert users to warning messages
	Safety Alert Symbol: Danger	Failure to obey this warning WILL result in death or serious injury to yourself or others
	Safety Alert Symbol: Warning	Failure to obey this warning CAN result in death or serious injury to yourself or others
	Safety Alert Symbol: Caution	Failure to obey this warning MAY result in death or serious injury to yourself or others

1.1 Safety Instructions

WORK AREA SAFETY

1. Keep your work area clean and well-lit. cluttered workbenches and dark areas invite accidents.
2. Do not operate power tools in explosive atmospheres, such as in the presence of flammable liquids, gases, or dust. Power tools create sparks that may ignite the dust or fumes.
3. Keep bystanders, children, and visitors away while operating a power tool. Distractions can cause you to lose control.
4. Make your workshop childproof with padlocks and master switches. Lock tools away when not in use.
5. Make sure the work area has ample lighting so you can see the work and that there are no obstructions that will interfere with the safe operation before using your power tool.

PERSONAL SAFETY

1. Know your power tool. Read the operator's manual carefully. Learn the power tools applications and limitations, as well as the specific potential hazards related to this tool.
2. Stay alert, watch what you are doing, and use common sense when operating a power tool.
3. Do not use tools while tired or under the influence of drugs, alcohol, or medication. A moment of inattention while operating power tools may result in serious personal injury.
4. Dress properly. Do not wear loose clothing or jewelry. Pull back long hair. Keep your hair, clothing, and gloves away from moving parts. Air vents often cover moving parts and should also be avoided. Loose clothing, jewelry, or long hair can be caught in moving parts.
5. Avoid accidental starting. Be sure the switch is in the "OFF" position before plugging in. Do not carry tools with your finger on the switch. Carrying tools with your finger on the switch or plugging in tools that have the switch in the "ON" position invites accidents.
6. Remove adjusting keys or wrenches before turning the tool "ON". A wrench that is left attached to a rotating part of the tool may result in personal injury.
7. Do not overreach. Keep proper footing and balance at all times. Proper footing and balance enable better control of the tool in unexpected situations.
8. Always secure your work. Use clamps or a vise

to hold work when practical. It is safer than using your hand and frees both hands to operate the tool.

9. Use safety equipment. Always wear eye protection. Dust masks, non-skid safety shoes, hard hats, or hearing protection must be used for appropriate conditions.
10. Do not use a ladder or unstable support. Stable footing on a solid surface enables better control of the tool in unexpected situations.

TOOL USE AND CARE SAFETY

WARNING

BE SURE to read and understand a instructions before operating this power tool.

1. Always use clamps or other practical ways to secure and support the workpiece to a stable platform. Holding the work by hand or against your body is unstable and may lead to loss of control.
2. Do not force the tool. Use the correct tool and blade for your application. The correct tool and blade will do the job better and safer at the rate for which it is designed.
3. Do not use the tool if the switch does not turn it "ON" or "OFF". Any tool that cannot be controlled with the switch is dangerous and must be repaired.
4. Disconnect the plug from the power source before making any adjustments, changing accessories, or storing the tool. Such preventive safety measures reduce the risk of starting the tool accidentally.
5. Never leave the tool running. Always turn it off. Do not leave the tool until it comes to a complete stop.
6. Store idle tools out of the reach of children and other untrained persons. Tools are dangerous in the hands of untrained users.
7. Maintain tools with care. Keep cutting tools sharp and clean. Properly maintained tools with sharp cutting edges are less likely to bind and are easier to control.
8. Check for misalignment or binding of moving parts, breakage of parts, and any other condition that may affect the tool's operation. If damaged, have the tool serviced before using. Many accidents are caused by poorly maintained tools.
9. Use only accessories that are recommended for this tool. Accessories that may be suitable for one tool may become hazardous when used on another tool.

ELECTRICAL SAFETY

1. Avoid body contact with grounded surfaces such as pipes, radiators, ranges, and refrigerators. There is an increased risk of electric shock if your body is grounded.
2. Do not expose power tools to rain or wet conditions. Water entering a power tool will increase the risk of electric shock.
3. Do not abuse the cord. Never use the cord to carry the tool or pull the plug from an outlet. Keep the cord away from heat, oil, sharp edges, and moving parts.
4. Replace damaged cords immediately. Damaged cords increase the risk of electric shock.

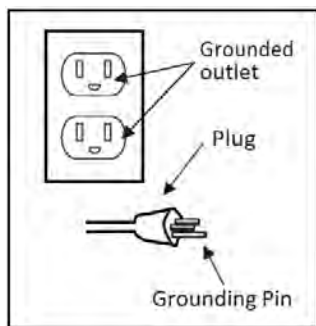

Diagram 1. Electrical Safety Guide

NOTE

This compressor should be used on a nominal 220V grounded circuit. Use a powercord that is equipped with a grounding plug. Verify that the compressor is plugged into an outlet that has the same configuration as the plug. Do not use an adaptor with this compressor.

EXTENSION CORDS

⚠ CAUTION

Keep the extension cord clear of the working area. Position the cord so that it will not get caught on lumber, tools, or other obstructions while you are working with a power tool.

⚠ WARNING

Check the extension cords before each use. Never use the tool with a damaged cord since touching the damaged area could cause electrical shock, resulting in serious injury.

As the distance from the supply outlet increases you must use a heavier gauge extension cord. Using the extension cords with inadequately sized wire causes a serious drop in voltage, resulting in loss of power and possible product damage. Refer to the table below to determine the required minimum wire size.

MINIMUM GAUGE FOR EXTENSION CORDS					
(When using 220 volts only)					
Ampere Rating		Total Length Of Cord			
More Than	< Less Than	25ft.	50ft.	100ft.	150ft.
0	6	18	16	16	14
6	10	18	16	14	12
10	12	16	16	14	12
12	16	14	12	Not Recommended	

Diagram 2. Minimum Gauge for Extension Cords

2. Parts and Specifications

Read this owner's manual before operating your air compressor. Familiarize yourself with the location and function of the controls and features. Save this manual for future reference.

Diagram 3. Air Compressor Parts

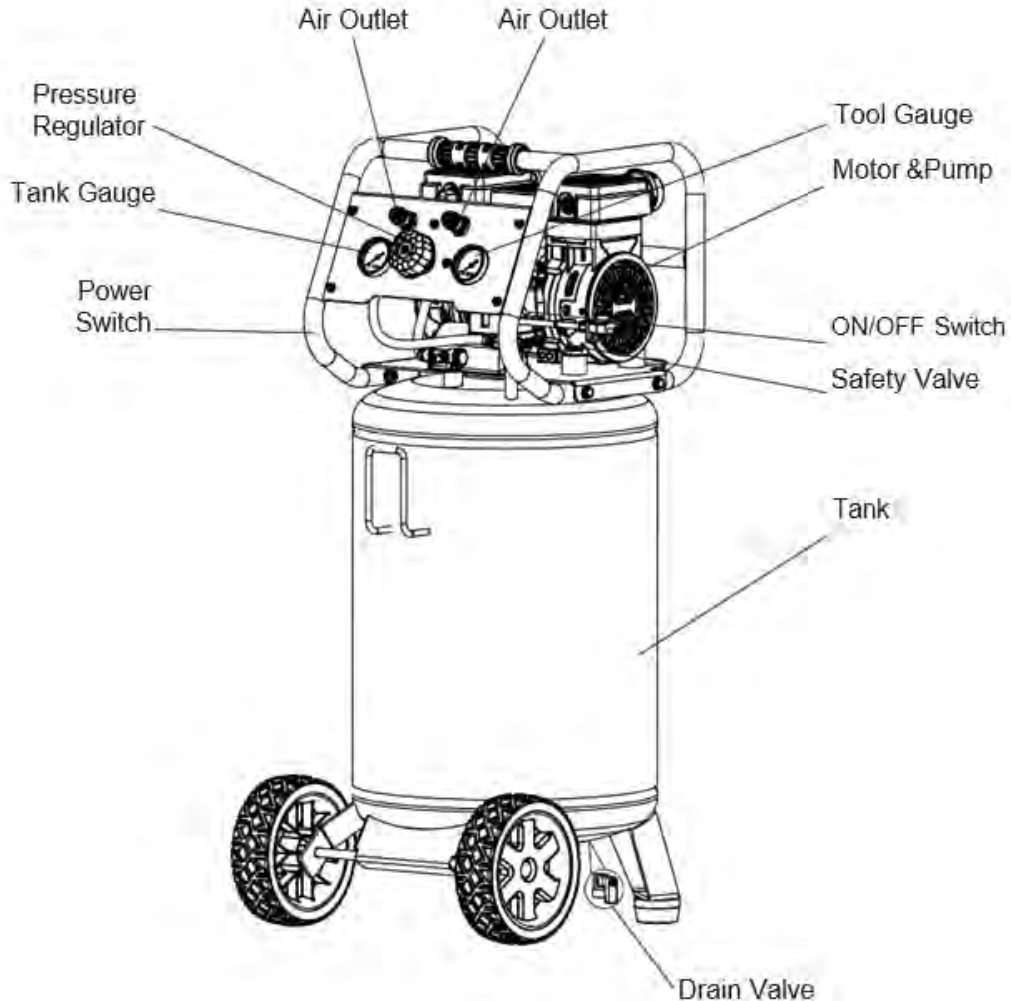



















Table 2. General Specifications

Model No.:	PCSS2020
Motor:	220V-230V~, 60Hz, Induction
Running Horsepower:	2.0 HP
Input Power:	1500W
Tank Size:	20 Gallons / 75 Liters
Air Delivery:	127/L MIN @ 6.2 BAR
Maximum Pressure:	165 PSI
Pump Design:	Oil-free, Direct Drive
Power Cord:	SJT 16AWG 3C X 1.8m
Net Weight:	49 kg
Gross Weight:	52 kg
Unit Dimensions (LxWxH):	520 x 445 x 1050 mm
Packaging Dimensions (LxWxH):	550 x 465 x 1068 mm

3. Tool Compatibility Chart

Table 3. Tool Compatibility Chart

RECOMMENDED TOOL USAGE		
Refer to specific tool requirements		
Brad Nailer		
Drill		
Finishing		
Flooring Nailer		
Framing Nailer		
Grease/ Caulking Gun		
Hammer/Chisel		
Impact Wrenches		
Inflation/Recreation		
Paint Sprayer		
Roofing Nailer		
Shears		
Angle Grinder		
Cut-off Tool		
Sander/ Lijadora		
 Recommended Use		Intermittent Use

SAVE THESE INSTRUCTIONS



Check the manufacturer's maximum pressure rating for air tools and accessories. The regulator outlet pressure must never exceed the maximum pressure rating.

4. Important Information

This air compressor is ideal for a wide range of job site applications. The 20-gallon design provides optimum pressure. It features a 2.0 HP induction motor and an oil-free pump. The procedures described in this manual are solely for the PCSS2020 air compressor at a maximum pressure of 165 PSI.

NOTE

Always ensure the use if appropriately matched air tools with your air compressor. Be sure that the air compressor being used can supply the appropriate volume, pressure, and delivery rate of air to the tool(s) without running continuously. Using tools or combinations voids the air compressor guarantee/warranty.

5. Product Features

Electric Motor

The motor is used to power the pump. It is equipped with a thermal overload protector. If the motor overheats for any reason, the thermal overload protector will shut down to prevent the motor from being damaged.

Air Compressor Pump

The pump compresses the air and discharges it into the tank via the piston that moves up and down in the cylinder.

Safety Valve

This valve is used to prevent the compressor from building too much pressure. If the pressure reaches the preset level of the motor, it will automatically pop open. You can also pull the ring on the valve to open manually.

Air Pressure Regulator

The regulator is used to adjust the pressure inside the line to the tool that is being used. Turn the knob clockwise to increase the pressure and counter-clockwise to decrease the pressure.

Tank Pressure Gauge

The gauge measures the pressure level of the air that is stored in the tank. It cannot be adjusted by the operator and it does not indicate the pressure inside the line.

Tool Pressure Gauge

The gauge measures the regulated outlet pressure.

Air Outlet (Universal Coupler)

The outlet is connected to the ¼" (6.4 mm) NPT air hose.

Tank Drain

The tank drain is used to remove moisture from the air tank after the compressor is shut off.

Air Tank

The tank is where the compressed air is stored.

Power Cord

This compressor should be used on a nominal 220V grounded circuit. Use a power cord that is equipped with a grounding plug. Verify that the compressor is plugged into an outlet that has the same configuration as the plug. Do not use an adaptor with this compressor.

6. Assembly

- Unpack the air compressor unit. Inspect the unit for damage. If the unit has been damaged, contact the retailer immediately.
- Check the air compressor's identification label to ensure that you have purchased the intended model and that it has the required pressure rating for its intended use.

6.1 Packaging Contents



DESCRIPTION	QTY	ILLUSTRATION
Air Compressor	1	
Owner's Manual	1	

Table 4. Packaging Contents

6.2 Positioning of the Air Compressor

1. Position the air compressor (1) near an electrical outlet (2) (FIG. A).
2. The compressor must be at least 12" (31cm) from any wall (3) or obstruction, in a clean, well-ventilated area to ensure sufficient airflow and cooling (FIG. A).
3. Place the air compressor on the floor or a hard, level surface.

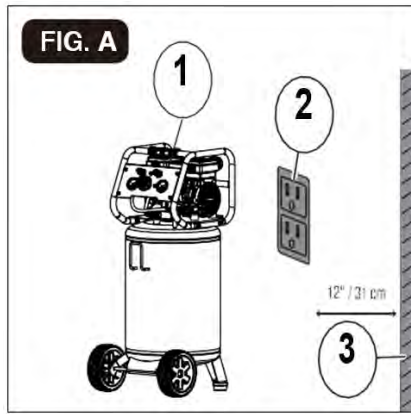

Diagram 4. Figure A

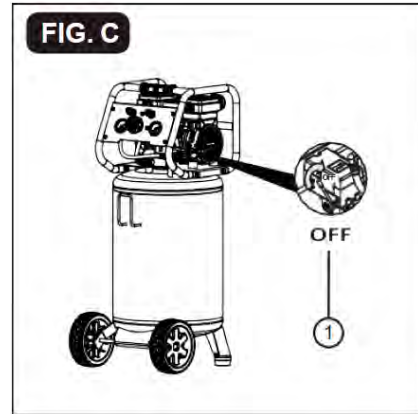

Diagram 6. Figure C

7. OPERATION

7.1 Before Starting Check Safety Valve

Before starting the compressor, pull the ring on the safety valve to make sure that the safety valve operates freely. If the valve is stuck or does not operate smoothly, contact a trained service technician (Fig. B).

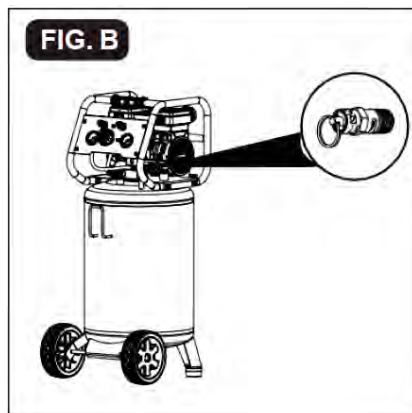

Diagram 5. Figure B

7.2 Starting the Compressor

1. Set the power switch to the OFF position (Fig. C).

2. Turn the air pressure regulator knob counter-clockwise until it stops (Fig. D).

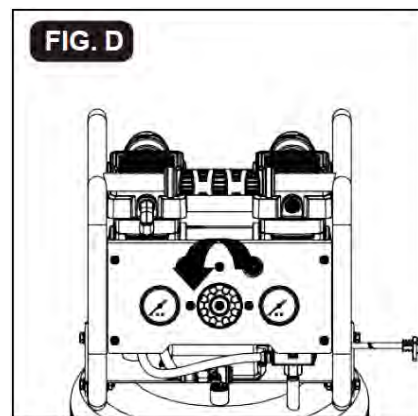

Diagram 7. Figure D

3. Connect the air hose (1) to the compressor's air outlet (universal coupler) (2) with the universal quick plug (3) (Fig. E).

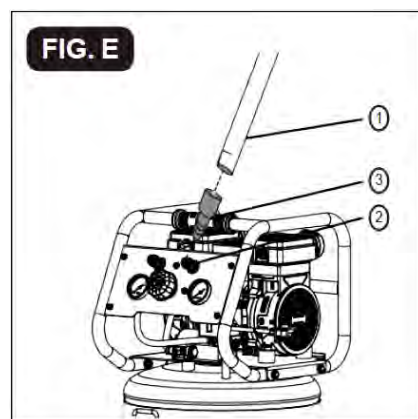

Diagram 8. Figure E

NOTE

Attach the air hose and accessories (not provided). Apply a plumber's tape on all the threads to prevent air leakage.

- Attach the hose and accessories (**Fig. F**).

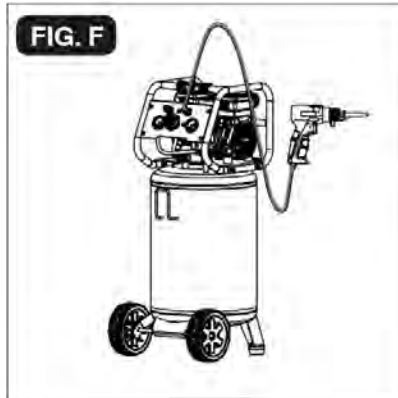

Diagram 9. Figure F

⚠ WARNING

High-pressure air could result in death or serious injury. Never operate above the maximum operating pressure of the spray gun or tool.

⚠ WARNING

Hot compressor surfaces could result in serious injury. Allow the compressor to cool before touching it.

NOTE

If the pump has been transported or turned upside down (even partially), allow the pump to sit in a normal, upright position (**Fig. A**) for approximately 10 minutes before starting.

- Close the tank drain (1). Plug in the power cord (2) (**Fig. G**).

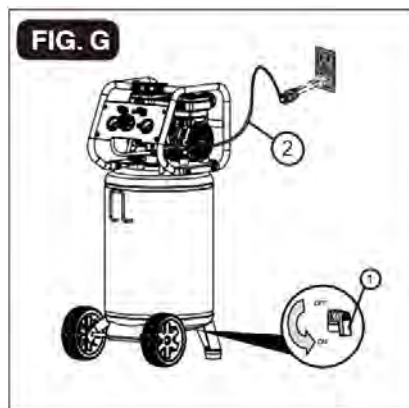

Diagram 10. Figure G

- Set the power switch to the ON position and allow the tank pressure to build. The motor will stop when tank pressure reaches cut-out pressure (**Fig H**).

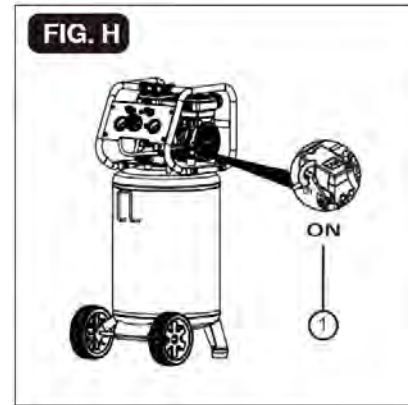

Diagram 11. Figure H

7.3 Stopping the Compressor

- Set the power switch (1) to the OFF position.
- Unplug the power cord (2).
- Reduce the pressure in the tank through the outlet hose. Pulling the safety valve ring (3) and keeping it open will also reduce the pressure in the tank (**Fig. I**).
- Set tank drain (4) (**Fig. I**) to OFF to ensure the tank is drained.

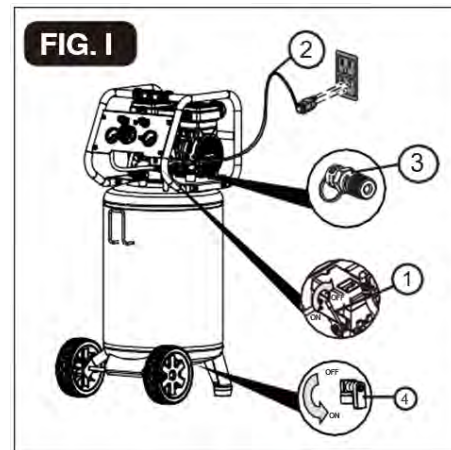

Diagram 12. Figure I

⚠ WARNING

Risk of serious eye injury from moisture and debris. Always wear ANSI Z87.1 safety goggles when opening the tank drain.

High-pressure air could result in death or serious injury. Shut off the unit, unplug, and release air pressure before servicing.

⚠ CAUTION

High-pressure air containing water condensation could result in minor or moderate injury. Do not spray at any person.

7.4 Draining the Tank

1. Set the power switch to the **(OFF)** position.
2. Turn the regulator knob counter-clockwise to set the outlet pressure to zero.
3. Pull and hold the ring on the safety valve, allowing air to bleed from the tank until air pressure is minimized.
4. Place a suitable container under the unit to catch any water.
5. Slightly tilt the unit and turn the tank drain counter-clockwise to open.
6. After the water has been drained, close the tank drain (clockwise) and store safely.

8. MAINTENANCE AND STORAGE

Table 5. Maintenance and Storage

TASK	DESCRIPTION	SERVICE INTERNAL
Drain the tank	To prevent corrosion inside the tank, the condensation must be drained at the end of every workday. Be sure to wear protective goggles. Relieve the air pressure in the system and then open the drain valve on the bottom of the tank.	Daily
Check the relief valve	Pull the relief valve on the ring daily to ensure that it is operating properly and to clear the valve of any possible obstructions.	Daily
Test for leakage	Check all connections to see if tight. A small leak of any part (the tank, hoses, pipe connections or transfer tubes) will reduce	Monthly
Storage	Before storing the unit for a long period, use an air blow gun to clean all the dust and debris from the compressor. Disconnect and coil the power cord. Pull the pressure relief valve to release all pressure from the tank. Drain all moisture from the tank. Cover the entire unit to protect it from moisture and dust.	Before prolonged storage

⚠ WARNING



Always shut off and unplug the unit and relieve all air pressure from the system before performing.

9. TROUBLESHOOTING

Table 6. Troubleshooting

PROBLEM	POSSIBLE CAUSE	SOLUTIONS
The motor will not run or start	The power cord is not plugged in.	Plug the power cord into a grounded outlet.
	The power switch is in the O (OFF) position.	Set the power switch to the ON position.
	The extension cord is the wrong wire gauge or is too long.	Check extension cord information (page 3) for the proper wire gauge and cord length.
	The motor's thermal overload protection has tripped.	Turn the air compressor off, unplug the power cord, and wait until the motor has cooled down. Plug in the power cord only after the motor has cooled down, and wait for at least 5 minutes to make sure the thermal overload protector has recovered.
	A fuse has blown or a circuit breaker has been tripped.	Replace the fuse or reset the circuit breaker.
		Verify that the fuse has the proper amperage.
		Check for low voltage conditions.
	The air tank pressure exceeds the preset power switch limit.	The motor will start automatically when the tank pressure drops below the cut-in pressure.
	The safety valve is stuck open.	Clean or replace the safety valve.
Electrical connections are loose.	Contact an authorized service center.	
The motor, capacitor, or safety valve is defective.	Contact an authorized service center.	
The motor runs continuously when the power switch is in the ON position.	The power switch does not shut off the motor when the air compressor reaches the cut-out pressure and the safety valve activates.	Set the power switch to the OFF position. If the motor does not shut off, unplug the air compressor. If the power switch is defective, replace it.
	The compressor's capacity is not enough.	Check the air requirements of the accessory that is being used. If it is higher than the CFM (Cubic Feet per Minute) and pressure supplied by the compressor (page 4), a larger capacity air compressor is needed. Most accessories are rated at 25% of actual CFM while running continuously.
The regulator does not regulate the pressure.	The regulator or its internal parts are dirty or damaged.	Replace the regulator.
The pressure is low or there is not enough air.	There is a leak at one of the fittings.	Check the fittings with soapy water. Tighten or reseal leaking fittings (apply plumber's tape on threads). Do not over-tighten.
	The tank drain is open.	Close the tank drain.
	The air intake is restricted.	Clean or replace the air filter element.
	Prolonged excessive use of air.	Decrease the amount of air used.
	There is a hole in the air hose.	Check the air hose and replace it if necessary.
	The tank leaks.	Replace the tank immediately. Do not attempt to repair it.
There is moisture in the discharged air.	The valve is leaking.	Check for worn parts and replace them if necessary.
	There is condensation in the air tank caused by a high level of atmospheric humidity or because the air compressor has not been running long enough.	Drain the air tank after each use. Drain the air tank more often in humid weather and use an air-line filter.
The compressor overheats.	The ventilation is inadequate.	Relocate the compressor to an area with cool, dry, and well-circulated air.
	Cooling surfaces are dirty.	Clean all cooling surfaces on the pump and the motor thoroughly.
	The valve is leaking.	Replace worn parts and reassemble using the new plumber's tape.

10. SERVICE INFORMATION

HOW TO ORDER REPLACEMENT PARTS

Even quality-built equipment such as the air compressor you have purchased will need occasional replacement parts to maintain its good condition over the years.

To order replacement parts and consumable parts, please contact Promate Service and be ready with the following information:

1. Model No., Serial No. and all specifications that are shown on the Model No./Serial No. plate.
2. Part numbers or numbers as shown in the Parts List section ().
3. A brief description of the trouble with the air compressor.

LIMITED WARRANTY

Warranty Coverage:

Powertech Asia Pacific Inc., (the Company) warrants to the original retail customer that it will repair or replace, free of charge, any parts found by the Company or its authorized service representative to be defective in material or workmanship. This warranty covers the cost of replacement parts and labor for defects in material or workmanship.

Not Covered:

- a. Shipping/Handling charges for sending the product to the Company or its authorized service representative for warranty service. Shipping/Handling repaired or replaced products to the customer; these charges must be borne by the customer.
- b. If a separate operator's manual and engine warranty from the engine manufacturer is included with this product, only that warranty will apply to the engine.
- c. Damage caused by abuse, accident, the effects of corrosion, erosion, and normal wear and tear.

- d. Warranty is void if the customer fails to install, maintain, and operate the product in accordance with the instructions and recommendations of the Company set forth in the owner's manual, or if the product is used as rental equipment.
- e. The Company will not pay for repairs or adjustments to the product, or for any costs of labor performed without the Company's prior authorization.
- f. Consumable parts such as battery, spark plugs, and air cleaner

Warranty Period: One (1) year from the date of purchase on products used solely for consumer applications; if a product is used for business or commercial applications, the warranty period will be limited to ninety (90) days from the date of purchase. For warranty service, the customer must provide dated proof of purchase and must notify the company within the warranty period.

EXCLUSIONS AND LIMITATIONS: THE COMPANY MAKES NO OTHER WARRANTY OF ANY KIND, EXPRESS OR IMPLIED. IMPLIED WARRANTIES, INCLUDING WARRANTIES OF MERCHANTABILITY AND OF FITNESS FOR A PARTICULAR PURPOSE, ARE HEREBY DISCLAIMED. THE WARRANTY SERVICE DESCRIBED ABOVE IS THE EXCLUSIVE REMEDY UNDER THIS WARRANTY; LIABILITY FOR INCIDENTAL AND CONSEQUENTIAL DAMAGES IS EXCLUDED TO THE EXTENT PERMITTED BY LAW.

This warranty gives you specific legal rights, and you may also have other rights which vary from state to state. Some states do not allow a disclaimer of implied warranties or the exclusion or limitation of incidental and consequential damages, so the above disclaimers and exclusions may not apply.



CONTACT THE POWERTECH Asia Pacific Inc.,
PRODUCT SERVICE DEPARTMENT AT (02) 8 984 2620 | (+63) 9338373922
service@powertechasiapacific.com www.facebook.com/PromateServicePH/

(MAIN) #420 Diamond Warehouse Compound, F Legaspi St., Maybunga Pasig City 1607
(DAVAO) Space 10 & 11 Jin-Long Complex R. Castillo St. Agdao District, Davao City 800



11. EXPLODED VIEW AND PARTS LIST

Diagram 13. PCSS2020 Exploded View

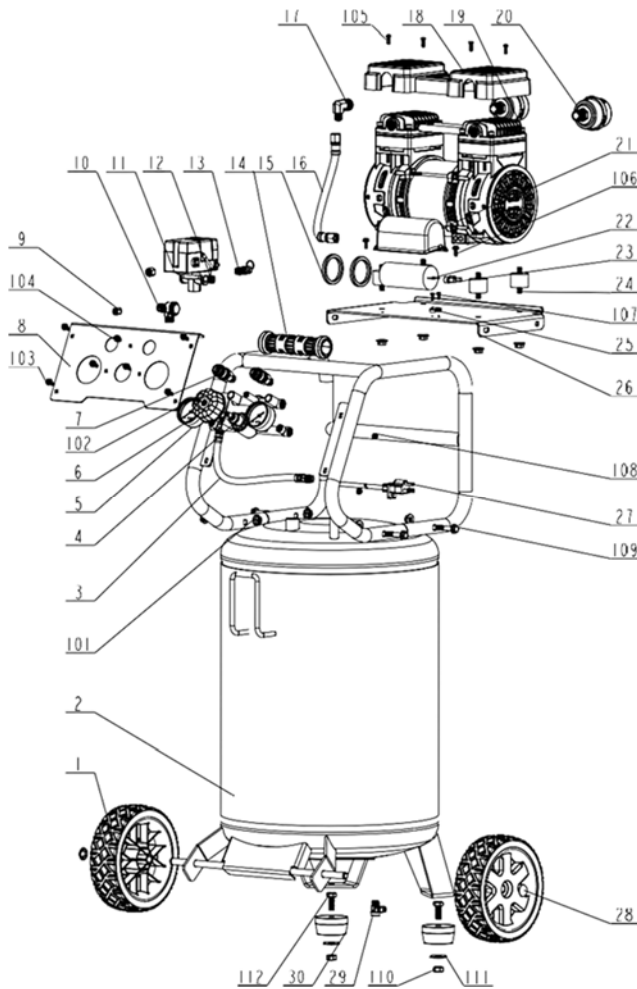

Table 7. PCSS2020 Parts List

NO.	DESCRIPTION	QTY
1	Roller Assembly	2
2	Gas Tank Components	1
3	Rubber Hose	1
4	Pressure Regulator Valve	1
5	Pressure Gauge	2
6	Pressure Regulator Knob	1
7	Quick Connector	2
8	Control Panel	1
9	Unload Aluminum Pipe	1
10	Check Valve	1
11	Pressure Switch	1
12	Hexagonal Plug	1
13	Safety Valve	1
14	Handle Cover	1
15	Capacitor Fixing Ring	2
16	Hose	1
17	Right Angle Elbow	1
18	Heat Shield Assembly	1
19	Motor Pump Head Assembly	1
20	Air Filter	2
21	Capacitor Cover	1
22	Capacitor	1
23	Crimp Cap	2
24	Shock Absorbing Pads	4
25	Crimping Board	1
26	Motor Fixing Plate	1
27	Power Cord	1
28	Stuck Hat	2
29	Drain Valve	1
30	Foot Pads	2
101	Flange Nut M8	8
102	Screw M4x10	1
103	Flange Bolt M5x12	4
104	Flange Bolt M5x12	3
105	Screw M4x17	4
106	ST4.8x14F Cut Tail Screw	2
107	Screws With Washers ST3.9x14F	2
108	Flange Nut M5	4
109	Flange Bolt M8X40	4
110	Hexagonal Nut M10	2
111	Flat Washer 10	2
112	Bolt M10X25	2

Diagram 14. PCSS2020 Motor Pump Head Exploded View

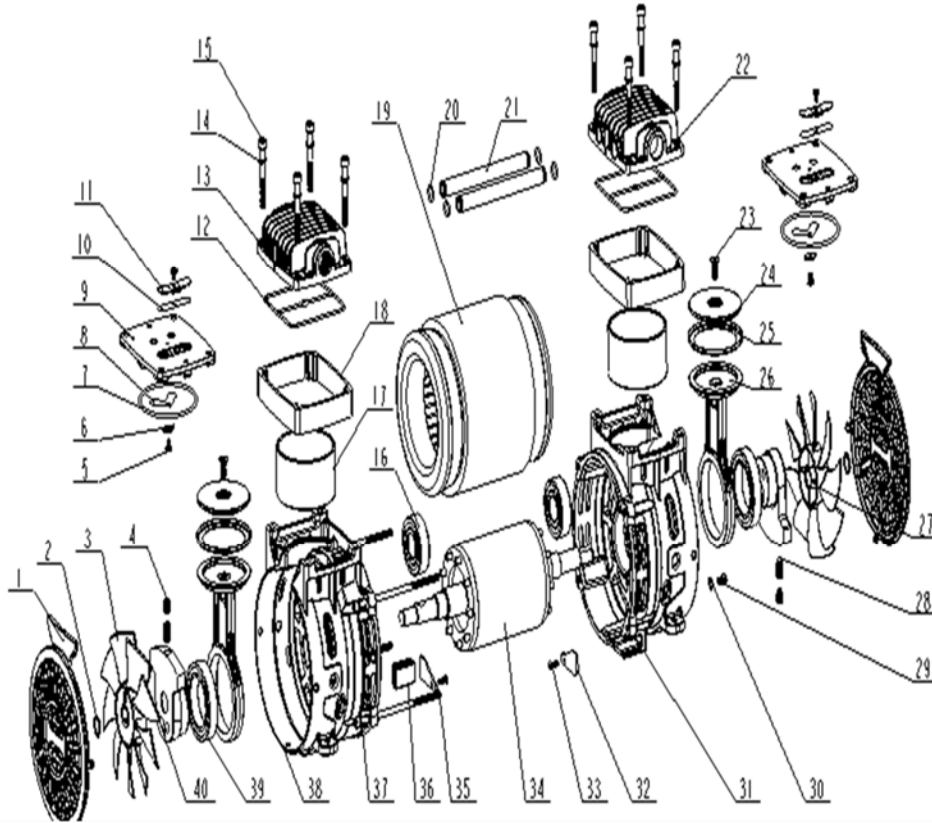

Table 8. PCSS2020 Motor Pump Head Parts List

NO.	DESCRIPTION	QTY	NO.	DESCRIPTION	QTY
1	End Cover	2	21	Pipe	2
2	External circlip ϕ 13	2	22	Cylinder Head A	1
3	Fan B	1	23	Screw M6x16	2
4	Screw M8x10	2	24	Connecting Rod Cover	2
5	Screw M4x8	2	25	Piston Ring	2
6	Press Plate for intake valve	2	26	Connecting Rod	2
7	Gasket O-Ring	2	27	Fan A	1
8	Intake Valve Flake	2	28	Screw M8x15	2
9	Valve Plate	2	29	Screw M5x8	1
10	Exhaust Valve Flake	2	30	Lock Washer ϕ 5	1
11	Limiter	2	31	Crankcase A	1
12	Gasket Seal Ring	2	32	Platen	2
13	Cylinder Head B	1	33	Screw M4x8	2
14	Spring Washer ϕ 6	8	34	Rotor	1
15	Screw M6x50	8	35	Pipe	2
16	Bearing 6204-RZ	2	36	Cylinder Head A	1
17	Cylinder	2	37	Screw M6x16	2
18	Bushing	2	38	Connecting Rod Cover	2
19	Stator	1	39	Piston Ring	2
20	Pipe O-Ring	4	40	Connecting Rod	2